

ISUZU

SPECIFICATIONS

NLS 200 All Wheel Drive Tipper



AUSTRALIA'S TOP SELLING TRUCK BRAND SINCE 1989.

AT A GLANCE

GVM	4,500 kg
GCM	6,000 kg (off road) 7,000 kg (on road)
Power	110 kW @ 2,800 rpm
Torque	375 Nm @ 1,600 – 2,800 rpm

ADVANCED TECHNOLOGY

Emissions: Euro V / ADR 80/03	Anti-lock Braking System (ABS)
Meets EEV emissions standard	Hill Start Aid (HSA)
Driver and passenger airbag with seatbelt pretensioner	Electric mirrors
ECE-R29 compliant cab	Independent front torsion bar suspension
On demand part-time all wheel drive system	



THE
one

ISUZU
RELIABILITY IS EVERYTHING

NLS 200 AWD Tipper

DRIVELINE AND CHASSIS SPECIFICATIONS

ENGINE: SITEC SERIES III 150 (ISUZU 4JJ1-TCS)

- Type:** 4 cylinder 16 valve with chain driven DOHC
Displacement: 2,999 cc
Compression ratio: 17.5:1
Bore x Stroke: 95.4 mm x 104.9 mm
Max power (DIN - NET): 110 kW (148 HP) @ 2,800 RPM
(JIS Gross): 114 kW (153 HP) @ 2,800 RPM
Max torque (DIN - NET): 375 Nm (277 lb.ft) @ 1,600 - 2,800 RPM
(JIS Gross): 388 Nm (286 lb.ft) @ 1,600 - 2,800 RPM
Induction system: Electronically controlled variable nozzle turbocharger with air-to-air intercooler.
Fuel injection: Direct injection high pressure common rail system.
Emission control system: Cooled EGR with exhaust Diesel Particulate Diffuser (DPD). ADR 80/03 (Euro V) compliant. EEV compliant.

CLUTCH

- Auto adjusting hydraulic control with vacuum assistance. Single plate 300 mm diameter.
- Total lining area: 847 cm²

TRANSMISSION

ISUZU MYY-5S

- 5 speed manual. Synchromesh on gears 1-5.
- Gear ratios (:1)

1st	2nd	3rd	4th	5th	Rev
5.979	3.434	1.752	1.000	0.795	5.701

TRANSFER GEARBOX:

- On demand part-time all wheel drive controlled by viscous coupling.
- Ratio 1.00:1

AXLES

Front: Isuzu FI026

- Fully independent wishbone. Full floating banjo type final drive with Birfield inner and outer joints and manual lock front hubs. 2,600 kg capacity.

Rear: Isuzu R050

- Full floating Banjo type. Four pinion limited slip differential. 5,000 kg capacity.
- Drive ratio: 4.300:1

SUSPENSION

Front:

- Torsion bar springs.
- Double acting hydraulic shock absorbers.

Rear:

- Taper leaf main spring, taper leaf helper spring.
- Double acting hydraulic shock absorbers.

BRAKES

- Auto adjusting front disc and rear drum brakes with dual circuit hydraulic control, vacuum assistance and electronic brake force distribution (EBD).
- ABS.
- Hill Start Aid (HSA).
- Front disc diameter: 285 mm
- Rear drum size: 320 x 75 mm
- 190 mm diameter drum park brake mounted on rear of transmission.
- Vacuum controlled exhaust brake.

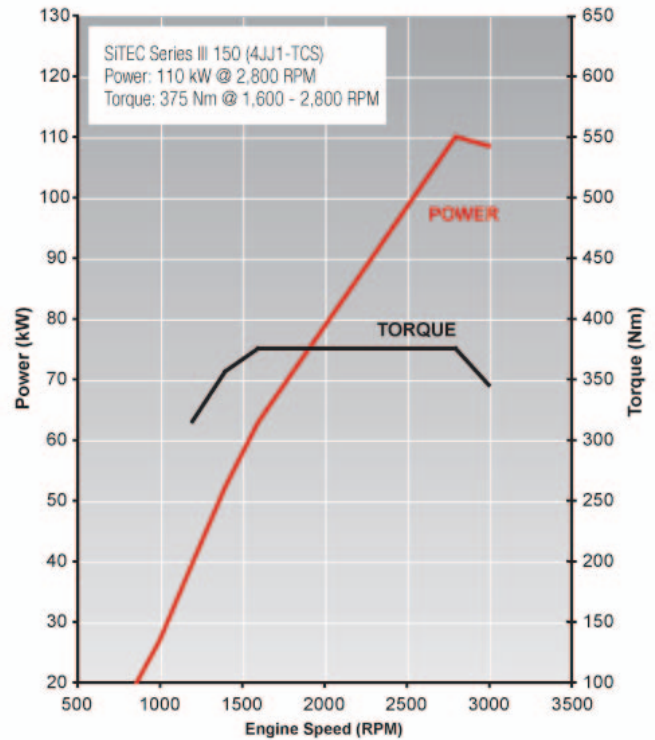

STEERING

- Power assisted rack and pinion.
- Turns lock to lock: 5.0
- Maximum angle: 35° (inside wheel) / 33° (outside wheel)

WHEELS AND TYRES

- 16 x 5.5J five stud steel wheels.
- 205/85R16 117/115L Bridgestone G557 Tubeless.
- Maximum tyre rating
 - Steer axle: 2,240 kg at 475 KPa inflation pressure
 - Drive axle: 4,240 kg at 475 KPa inflation pressure
- 1 frame mounted spare wheel and tyre assembly.

CHASSIS FRAME

- Cold rivetted ladder frame. SAPH440 weldable steel sidemembers.
- Frame dimensions:
 - Side rail (mm): 180 x 65 x 4.0
 - Rear frame width (mm): 700

TIPPER BODY

- All steel body with drop sides. Auto release removable tailgate.
- Auto release body lockdown hook.
- Shovel rack. LHS and RHS rope rails. Non-slip side steps.
- 20 sec. raise/20 sec. lower time.
- Cubic volume: 2.1m³
- Deck plate thickness: 3.2mm
- Side/front/tail plate thickness: 2.3mm

FUEL TANK

- Frame mounted 75L steel fuel tank.
- Lockable fuel cap.

ELECTRICAL SYSTEM

- 24 volt electrical system.
- 50 amp alternator.
- 4.0 kW starter motor.
- 2 x 80D26L (630 CCA) batteries connected in series.

CABIN SPECIFICATIONS AND APPOINTMENTS

CAB EXTERIOR

- All steel construction. High tensile steel used for cab underframe. Manual cab tilt to 45° with torsion bar assistance.
- Complies with ECE-R29 cab strength standard.
- Heavy duty non slip entry steps.
- 90° opening internally reinforced front doors.
- Water spray suppression guards and front mudflaps.
- Laminated windscreen with shade band.
- Two speed windscreen wipers with intermittent wipe mode.
- Halogen multi-reflector headlamps incorporating turn signals. Additional door mounted side indicator lamps.
- Combination brake, turn, reverse and marker lamps, registration plate illumination lamps. Extended wiring harness. Reverse alarm.
- Heated and powered exterior main mirrors with flat glass and additional independently adjustable convex “spot” mirrors.
- Body coloured grille.
- Body coloured impact resisting polycarbonate bumper with steel backing frame.

CAB INTERIOR

- Contoured adjustable driver's bucket seat.
- Front passenger bench seat with 2 seat capacity.
- 3-point lap sash seatbelts in all outboard seating positions. Driver and outboard front passenger seatbelts fitted with pretensioner. Centre seat lap belts.
- Driver and outboard front passenger airbag.
- Door and roof pillar entry assist grips.
- Full interior trim, padded roof lining and vinyl floor covering. Driver and passenger windscreen header storage shelf.
- Tilt/Telescopic adjustable steering column, soft feel urethane steering wheel.
- Electric windows.
- Central locking with remote keyless entry and immobiliser.
- Twin cup holders. 24V cigarette lighter. Dashboard hook.
- Front door mounted storage pockets and driver's side ashtray.
- Fully integrated air conditioning and heater/demister with 4-speed fan and outlets for windscreen, side windows, face and floor.
- Fluorescent type interior lamp with On/Door/Off switch.
- 2 DIN, two speaker radio/CD multimedia unit with 4.8" LCD touch screen and Bluetooth. Provision for SD card, USB and 3.5 mm plug inputs.
- DIN sized compartment for storage or for CB radio installation.

DRIVER CONTROLS

- Key-operated engine start/stop and steering lock. Engine idle speed control.
- HSA slow/fast engagement control and on/off switch.
- DPD regeneration.
- All wheel drive engage switch.
- **Left side combination stalk:** Windscreen wipers, washers and exhaust brake.
- **Right side combination stalk:** Turn signals and headlamps.
- Tip body raise and lower lever safety release mechanism.

INSTRUMENTATION

- Electronically driven speedometer and tachometer. Digital odometer with integrated dual tripmeter. Engine coolant temperature and fuel level gauges.
- **Warning lamps:** Check engine, oil pressure, ABS, SRS airbag, alternator charge, service brakes, park brake, seatbelt unfastened, low fuel level, transfer gearbox oil temperature.
- **Indicator lamps:** Warm up system, high beam, DPD status, exhaust brake, all wheel drive engaged, turn signals, PTO engaged.

OPTIONS AND GENUINE ACCESSORIES

Include the following (extra cost, request a brochure and further details from your Isuzu dealer):

- Satellite navigation - integrates with multimedia unit and includes NAVTEQ mapping.
- Up to three audio/visual reversing cameras - integrates with multimedia unit.
- Airbag compatible bullbar.



ISUZU
RELIABILITY IS EVERYTHING

WEIGHTS (kg)

Models	Ratings*		Loading Limit* (at ground)		Cab Chassis Mass #		
	GVM	GCM	Front	Rear	Front	Rear	Total
NLS 200 Tipper	4,500	6,000 kg (off road) 7,000 kg (on road)	2,240	4,240	1,715	1,175	2,890

Maximum Gross Trailer Mass: 750 kg (unbraked), 2,500 kg (braked) * Vehicle ratings and front/rear weight limits are subject to government regulatory requirements and weight distribution analysis. Consult your Isuzu dealer to select the correct vehicle for your specific application. # Cab chassis only as supplied and including 10 litres of fuel.

DIMENSIONS (mm)

Models	WB	OAL	OAW	OAH	FOH	ROH	RT	ORT	CW	KERB TO KERB
NLS 200 Tipper	2,740	5,085	1,995	2,190	1,100	1,200	1,425	1,860	1,770	10.1

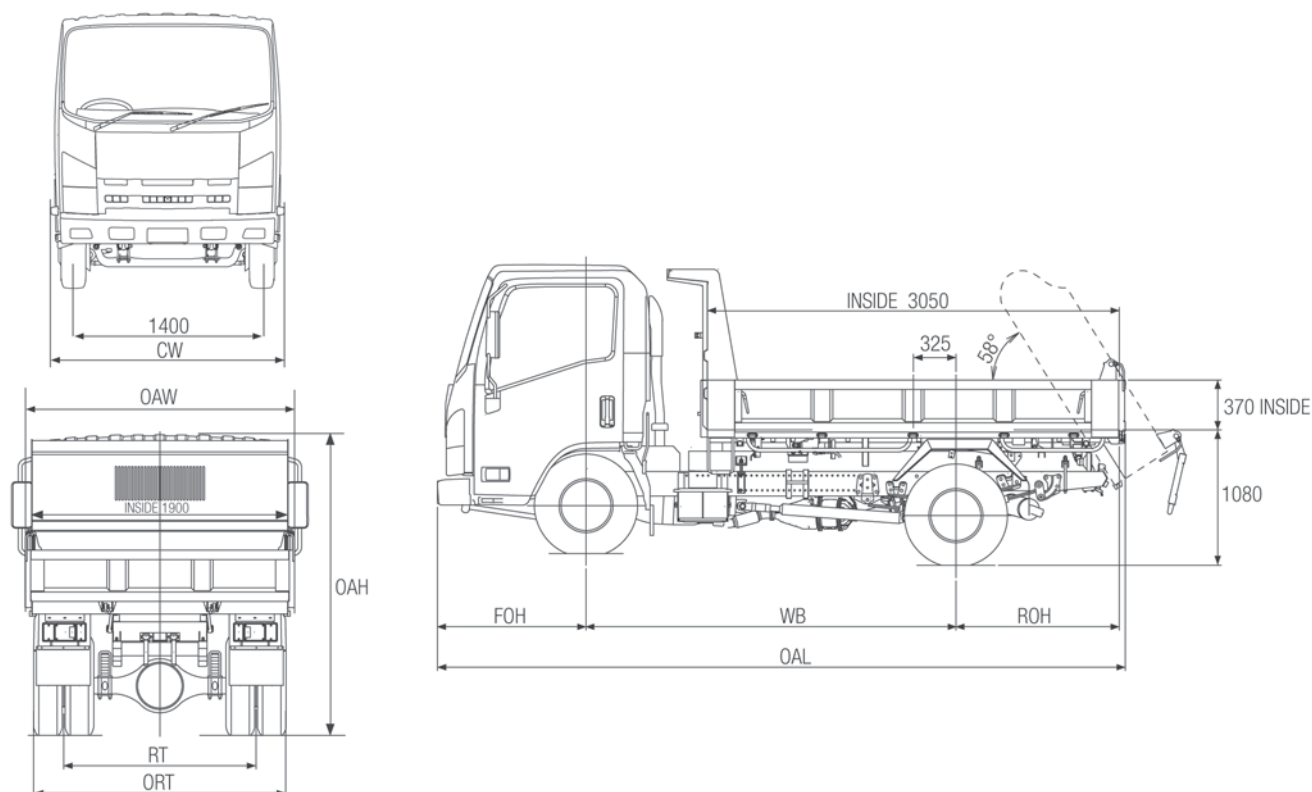

PERFORMANCE (calculated - typical paved road)

		Geared Speed* (top gear at peak power engine RPM)	Low Speed Gradeability (lowest forward gear assuming no wheel slip)	Engine Speed (top gear at 100km/h)
NLS 200 Tipper	At 4,500 kg GVM	112 km/h @ 2,800 RPM	52%	2,500 RPM

*Maximum speed achievable depends on vehicle frontal area as well as other factors. Consult your Isuzu dealer for more detailed information.

ISUZU WARRANTIES

STANDARD¹

New Vehicle 3 years • 100,000km • 2,000 hours

EXTENDED²

4 years • 200,000 km 5 years • 250,000 km 6 years • 300,000 km

Isuzu Assist - 24 hour roadside assistance (3 years, unlimited km's)*

ORDER CODES

Model	Code
NLS 200 Tipper	NH-NLSBA-A11

¹ Subject to the conditions outlined in the IAL New Vehicle Warranty, the Isuzu NLS model carries a standard factory warranty which covers the owner: (i) for the entire vehicle, for the first 36 months or 100,000 km or 2,000 hrs (whichever comes first), (ii) against cab perforation corrosion, for 36 months and unlimited kilometres. ² Extended Warranty as illustrated is available by purchase to cover the owner against the failure of original components, but may exclude some components and expendable items such as oil, filters, etc. Please consult with your Isuzu Dealer for full details obtained from a dedicated brochure available to customers. *Valid for three years from the date of new vehicle purchases.

ISUZU AUSTRALIA LIMITED ABN 97 006 962 572 ("IAL"). The information in this brochure was correct at time of printing, but all measurements, specifications and equipment are subject to change without notice. Some equipment may have been changed and/or is available at extra cost. IAL may make changes at any time without notice, in prices, colours, materials, equipment and models. IAL makes all reasonable attempts to ensure the availability of all vehicles and equipment. The information in this brochure is general in nature. Your Isuzu dealer can confirm all measurements, specifications and vehicle / equipment availability upon request.

TIC: Isuzu is a member of the Truck Industry Council - Safer Greener Essential.

May 2011. ARK0563



ISUZU
RELIABILITY IS EVERYTHING