

# ISUZU

## SPECIFICATIONS

### FTS 800 4x4

### FTS 800 4x4 Crew



FTS 800 Crew



FTS 800

AUSTRALIA'S TOP SELLING TRUCK BRAND SINCE 1989.

#### AT A GLANCE

GVM	13,900 kg
GCM	18,000 kg (off road) 20,500 kg (on road)
Power	176 kW @ 2,400 rpm
Torque	706 Nm @ 1,450 rpm

#### ADVANCED TECHNOLOGY

Emissions: Euro V / ADR 80/03	Full time 4WD with centre differential lock
Meets EEV emissions standard	Cruise control
Driver airbag with seatbelt pretensioner	Isri 6860 seat with integrated seatbelt
ADR42 compliant sleeper - except crew	Electric mirrors
ECE-R29 compliant cab	
90 amp alternator	



THE  
**one**

**ISUZU**  
RELIABILITY IS EVERYTHING

# FTS 4x4 Standard | PTO Crew | Crew PTO

## DRIVELINE AND CHASSIS SPECIFICATIONS

### ENGINE: SITEC SERIES III 235 (ISUZU 6HK1-TCN)

- Type:** 6 cylinder 24 valve SOHC  
**Displacement:** 7,790 cc  
**Compression Ratio:** 17.5:1  
**Bore x Stroke:** 115 x 125 mm  
**Max power (DIN-NET):** 176 kW (236 HP) @ 2,400 RPM  
**(JIS Gross):** 182 kW (244 HP) @ 2,400 RPM  
**Max torque (DIN-NET):** 706 Nm (521 lb.ft) @ 1,450 RPM  
**(JIS Gross):** 731 Nm (539 lb.ft) @ 1,450 RPM  
**Induction system:** Electronically controlled variable nozzle turbocharger with air-to-air intercooler.  
**Fuel injection:** Direct injection high pressure common rail system.  
**Emission control system:** Cooled EGR with exhaust Diesel Particulate Dif-fuser (DPD). ADR 80/03 (Euro V) compliant. EEV compliant.

#### ENGINE DRIVEN PTO (PTO models only):

- Constant mesh. Rotates at 0.7 x engine speed.
- 353 Nm maximum output torque.
- Anti-clockwise rotation when viewed from rear of engine.

### CLUTCH

- Air assisted hydraulic control. Single plate 381 mm diameter.
- Total lining area: 1,363 cm<sup>2</sup>

### TRANSMISSION

#### ISUZU MZW-6P

- 6 speed manual with air assisted shift.
- Synchromesh on gears 2-6. Triple cone synchromesh on 2nd and 3rd gears. Integral oil pump provides full pressure lubrication.
- PTO provision on LHS of transmission case. PTO drive from mainshaft gear.

#### Gear ratios (:1)

1st	2nd	3rd	4th	5th	6th	Rev
6.615	4.095	2.358	1.531	1.000	0.722	6.615

#### Transfer Gearbox: ISUZU TF56

- Full time 4WD with driver activated centre differential lock.
- High ratio 1.00:1, low ratio 1.913:1

### AXLES

#### Front: Isuzu FD047

- Full floating Banjo type. Birfield outer joints and permanently engaged hubs. 4,700 kg capacity.

#### Drive ratio 5.571:1

#### Rear: Isuzu R092

- Full floating Banjo type. 'No-spin' differential lock. 9,200 kg capacity.
- Drive ratio: 5.571:1

### SUSPENSION

#### Front:

- Single stage alloy steel taper leaf springs.
- Double acting hydraulic shock absorbers.

#### Rear:

- Multi leaf main spring, multi leaf helper spring.

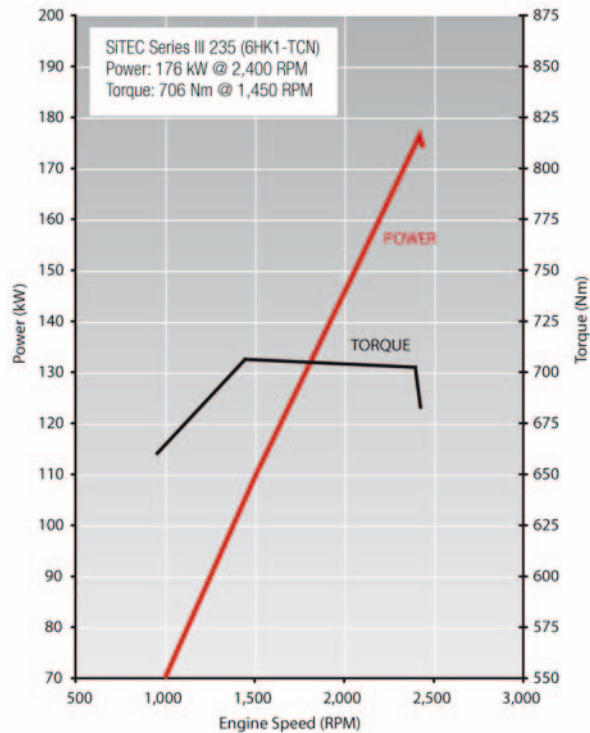

### BRAKES

- Dual circuit air over hydraulic front and rear drum brakes.
- Front drum size: 410 x 140 mm
- Rear drum size: 410 x 140 mm
- Spring park brake.
- Air controlled exhaust brake.
- Air dryer.

### STEERING

- Power assisted recirculating ball steering.
- Gear ratio: 18.1 - 22.4:1
- Turns lock to lock: 3.5
- Maximum angle: 34° (inside wheel) / 29° (outside wheel)

### WHEELS AND TYRES

- 22.5 x 7.50 eight stud steel wheels.
- 10R22.5 TL 144/142K Michelin XZY Tubeless.
- Maximum tyre rating:  
 Front axle: 5,600 kg  
 Rear axle: 10,600 kg
- Spare wheel and tyre assembly with winch type carrier.

## CHASSIS FRAME

- Cold rivetted ladder frame with parallel side rails. HT540A high tensile weldable steel sidemembers.
- Frame dimensions:
  - Side rail (mm): 253 x 80 x 7.5
  - Rear frame width (mm): 850

## FUEL TANK

- Frame mounted 200L steel fuel tank.
- Lockable fuel cap.

## ELECTRICAL SYSTEM

- 24 volt electrical system.
- 90 amp alternator.
- 24 Volt, 4.5 kW starter motor.
- **Single cab:** 2 x 115E41L (651 CCA) batteries connected in series.
- **Crew cab:** 2 x 80D26L (630 CCA) batteries connected in series.

## CABIN SPECIFICATIONS AND APPOINTMENTS

### CAB EXTERIOR

- All steel construction. High tensile steel used for cab underframe.
  - Single cab:** Manual cab tilt to 45° with torsion bar assistance.
  - Crew cab:** Electro-hydraulic cab tilt.
- Complies with ECE-R29 cab strength standard.
- **Single cab:** Liquid filled front and rear cab mounts.
  - Crew cab:** Rubber cab mounts.
- Heavy duty non slip entry steps.
- 90° opening internally reinforced front doors.
- Water spray suppression guards and front mudflaps.
- Laminated windscreen with shade band.
- Two speed windscreen wipers, with intermittent wipe mode.
- Halogen multi-reflector headlamps. Front panel mounted turn signals. Additional door mounted side indicator lamps.
- Combination brake, turn, reverse and marker lamps, registration plate illumination lamps. Extended wiring harness. Reverse alarm.
- Roof-mounted clearance lamps.
- Heated and powered exterior main mirrors with flat glass and additional powered convex "spot" mirrors.
- Body coloured grille.
- Body coloured steel air dam bumper.

### CAB INTERIOR

- Isri 6860 air suspension driver's seat with pneumatic lumbar support, height, rake and automatic weight adjustment.
- Front passenger adjustable bucket seat and front centre seat with folding seat back.
- **Crew cab:** Rear bench seat with 4 seat capacity.
- 3-point lap sash seatbelts in all outboard seating positions. Driver seatbelt with pretensioner integrated with driver seat. Centre seat lap belts.
- **Single cab:** ADR42 compliant sleeper.
- Driver airbag.
- Door and roof pillar entry assist grips. **Crew cab:** Full width rear grab rail with ashtray.
- Full interior trim, padded roof lining and vinyl floor covering. Driver and passenger windscreen header storage shelf.
- Tilt/Telescopic adjustable steering column, soft feel urethane steering wheel.
- Electric windows.
- Central locking with remote keyless entry and immobiliser.
- Twin cup holders. 24V cigarette lighter. Dashboard hook.
- Front door mounted storage pockets and driver's side ashtray.
- Centre console box with storage tray. Fold down storage tray behind centre seat backrest.
- Front passenger glovebox.

- Fully integrated air conditioning and heater/demister with 4-speed fan and outlets for windscreen, side windows, face and floor.
- Fluorescent type interior lamp with On/Door/Off switch.
- 2 DIN, two speaker radio/CD multimedia unit with 4.8" LCD touch screen and Bluetooth. Provision for SD card, USB and 3.5 mm plug inputs.
- DIN sized compartment for storage or for CB radio installation.

### DRIVER CONTROLS

- Key-operated engine start/stop and steering lock. Engine idle speed control.
- DPD regeneration.
- High/low range and centre differential lock switches.
- **Left side combination stalk:** Windscreen wipers, washers and exhaust brake.
- **Right side combination stalk:** Turn signals, headlamps and cruise control.

### INSTRUMENTATION

- Electronically driven speedometer and tachometer. Digital odometer with integrated dual tripmeter. Engine coolant temperature, fuel level and air pressure gauges.
- **Warning lamps:** Check engine, oil pressure, SRS airbag, alternator charge, service brakes, park brake, seatbelt unfastened, low air pressure, low fuel level, cab lock.
- **Indicator lamps:** Warm up system, high beam, DPD status, exhaust brake, low range engaged, centre differential lock engaged, turn signals, cruise control.
- Multi-information display. Shows service interval, instantaneous and average fuel consumption, DPD bar chart, hourmeter, voltmeter, time/day/date and includes 40-120 km/h adjustable vehicle speed warning.

### OPTIONS AND GENUINE ACCESSORIES

Include the following (extra cost, request a brochure and further details from your Isuzu dealer):

- Satellite navigation - integrates with multimedia unit and includes NAVTEQ mapping.
- Up to three audio/visual reversing cameras - integrates with multimedia unit.
- Airbag compatible bullbar.
- Air deflector.



**ISUZU**  
RELIABILITY IS EVERYTHING

### WEIGHTS (kg)

Models	Ratings*		Loading Limit* (at ground)		Cab Chassis Mass #		
	GVM	GCM	Front	Rear	Front	Rear	Total
FTS 800	13,900	18,000 kg (off road) 20,500 kg (on road)	4,700	9,200	3,070	1,915	4,985
FTS 800 PTO	13,900	18,000 kg (off road) 20,500 kg (on road)	4,700	9,200	3,130	1,930	5,060
FTS 800 Crew	13,900	18,000 kg (off road) 20,500 kg (on road)	4,700	9,200	3,260	1,980	5,240
FTS 800 Crew PTO	13,900	18,000 kg (off road) 20,500 kg (on road)	4,700	9,200	3,320	1,995	5,315

\* Vehicle ratings and front/rear weight limits are subject to government regulatory requirements and weight distribution analysis. Consult your Isuzu dealer to select the correct vehicle for your specific application. # Cab chassis only as supplied and including 10 litres of fuel.

### DIMENSIONS (mm)

Turn Circle (m)

Models	WB	OAL	FOH	ROH	EA	CE	RT	ORT	CH	FFA (unladen)	RFA (unladen)	RFH (unladen)	KERB TO KERB
FTS 800	4,250	7,405	1,255	1,900	3,350	5,340	1,795	2,365	2,910	1,100	1,165	1,195	17.5
FTS 800 Crew	4,250	7,405	1,255	1,900	2,625	4,648	1,795	2,365	3,045	1,095	1,160	1,185	17.5

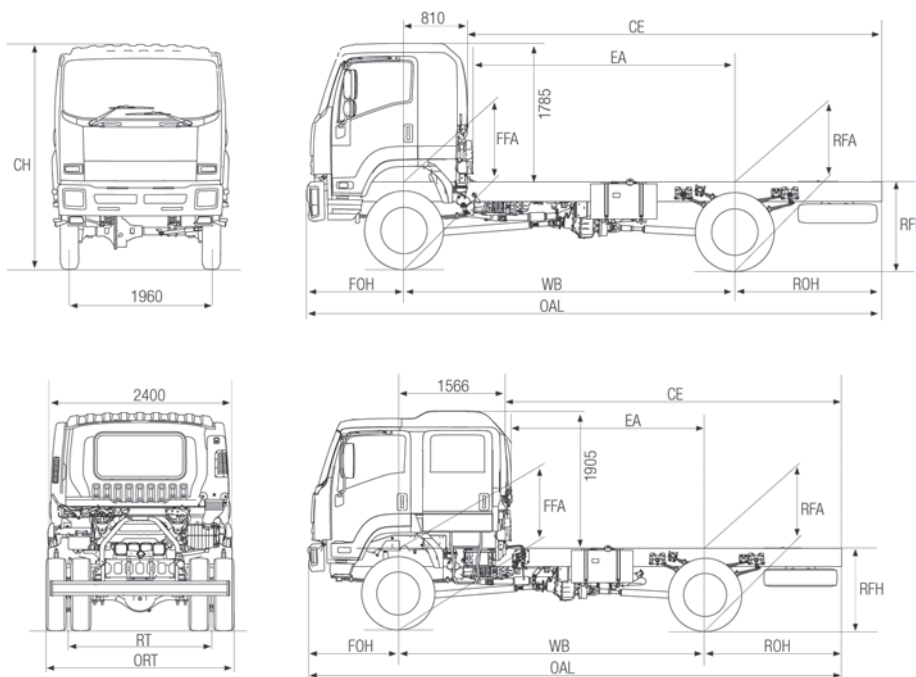

### PERFORMANCE (calculated - typical paved road)

		Geared Speed* (top gear at peak power engine RPM)	Low Speed Gradeability (lowest forward gear assuming no wheel slip)	Engine Speed (top gear at 100km/h)
FTS 800 4x4	At 13,900kg GVM	111 km/h @ 2,400 RPM	65%	2,165 RPM

\*Maximum speed achievable depends on vehicle frontal area as well as other factors. Consult your Isuzu dealer for more detailed information. Vehicle speed is limited to 100 km/h.

### ISUZU WARRANTIES

STANDARD <sup>1</sup>		
New Vehicle	3 years • 150,000km • 2,500 hours	
Cab Perforation Corrosion	3 years • unlimited km's	
EXTENDED <sup>2</sup>		
4 years, 250,000km	5 years • 300,000km	6 years • 350,000km
Isuzu Assist - 24 hour roadside assistance (3 years, unlimited km's)*		

### ORDER CODES

Model	Code	Model	Code
FTS 800	FH-FTSJF-B11	FTS 800 Crew	FH-FTSLF-B11
FTS 800 PTO	FH-FTSJG-B11	FTS 800 Crew PTO	FH-FTSLG-B11

<sup>1</sup> Subject to the conditions outlined in the IAL New Vehicle Warranty, the Isuzu FTS models carry a standard factory warranty which covers the owner: (i) for the entire vehicle, for the first 36 months or 150,000 km or 2,500 hrs (whichever comes first). (ii) against cab perforation corrosion, for 36 months and unlimited kilometres. <sup>2</sup> Extended Warranty as illustrated is available by purchase to cover the owner against the failure of original components, but may exclude some components and expendable items such as oil, filters, etc. Please consult with your Isuzu Dealer for full details obtained from a dedicated brochure available to customers. \*Valid for three years from the date of new vehicle purchases.

ISUZU AUSTRALIA LIMITED ABN 97 006 962 572 ("IAL"). The information in this brochure was correct at time of printing, but all measurements, specifications and equipment are subject to change without notice. Some equipment may have been changed and/or is available at extra cost. IAL may make changes at any time without notice, in prices, colours, materials, equipment and models. IAL makes all reasonable attempts to ensure the availability of all vehicles and equipment. The information in this brochure is general in nature. Your Isuzu dealer can confirm all measurements, specifications and vehicle / equipment availability upon request.

TIC: Isuzu is a member of the Truck Industry Council - Safer Greener Essential.

April 2011.ARK0553



**ISUZU**  
RELIABILITY IS EVERYTHING